

SUPERSTAR E-3000/F

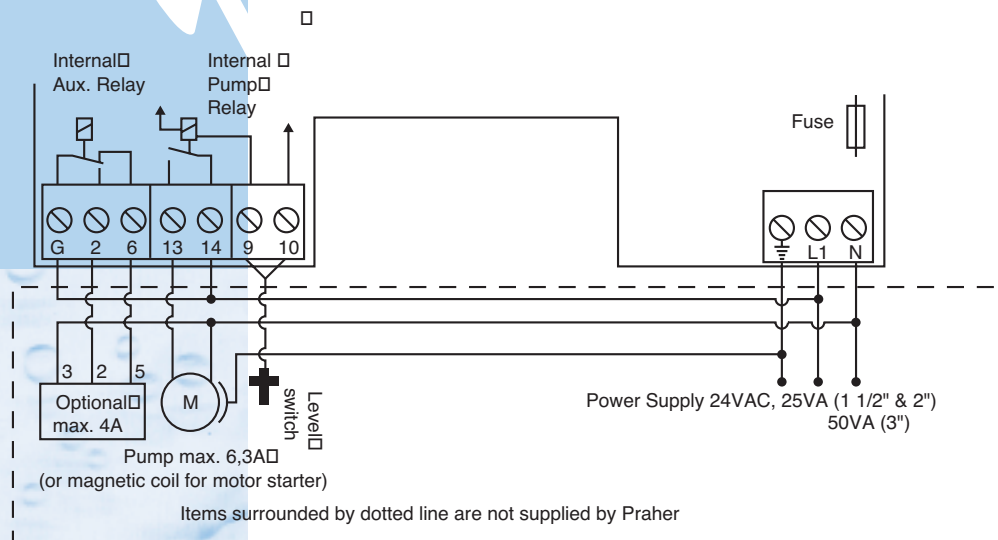

Power supply	24 VAC, 50 or 60Hz
Pump control relay (Terminal 13 & 14)	max. 6.3 Amp.
Ball valve auxiliary relay (Term. G, 2, & 6)	max. 4 Amp.
Enclosure	IP 54
Valve size	1 1/2" (70 GPM), 2" (120 GPM), 3" (280 U.S. GPM max.)
Back wash time	adjustable with built in potentiometer: 1 min. - 11 min.
Rinse time	adjustable with built in potentiometer: 20 sec. - 4 min. 20 sec.
Delayed pump cut in	20 sec.
Backwash timer	"Graesslin" -Analog-7 day, 24hr
Max. Valve operating pressure	50 psi
Fireman cycle delay time	adjustable with built in potentiometer: 25 sec. - 25 min.

SIDE MOUNTED VALVES

	1 1/2"	2"	3"
	inch	inch	inch
A	3.9	4.33	6.69
B	7.16	8.97	13.0
C	1.26	1.5	1.97
D	1.85	2.36	3.37
E	2.36	3.19	4.33
F	6.46	8.26	12.0
G	10.63	12.28	17.16
H	1.5	1.33	1.97
I	3.44	4.52	6.5
K	6.89	9.0	13.0
L	9.84	9.84	9.84
M	6.3	6.3	6.3
weight:	13 lbs.	14 lbs.	24 lbs.

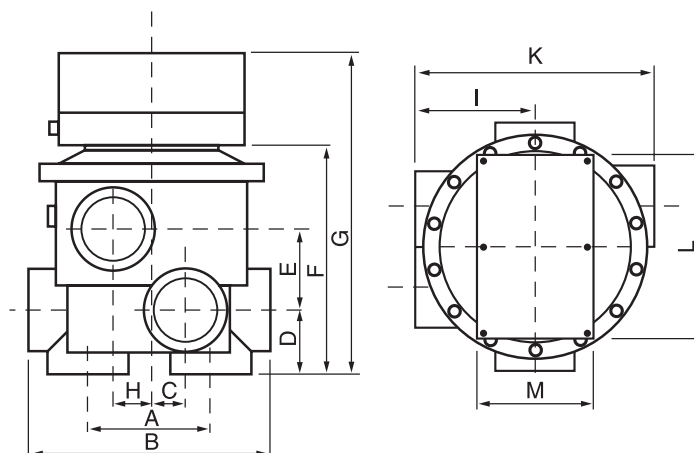

Also available are 1 1/2" and 2" top mounted valves.